

C1 M12

Material

Body: PC - Polycarbonate
Sensor: PPA - Polyphthalamide



How it works Mounted on the booster pumps up to 1CV (1 HP) or parallel pipe, closing the electrical contact (**reed switch**) when the water reaches the level of the internal sensor.

- Details**
- Transparent display that shows lack or presence of water;
 - On/Off SPST output;
 - Electrical outlet in M12 Plug.

- Typical applications**
- Display and signaling the presence of liquids in pipes;
 - Protects the pump against dry running.



Chemical products require preliminary tests to confirm compatibility.

Liquid with ferrous particles should be avoided.

Don't apply solvents or diluents, they cause chemical damage to polycarbonate.

Technical specifications

Maximum operating pressure	7bar
Operating temperature range	1°C to 60°C
Sealing	Sealant tape
Output connection	M12 male plug (2 pins) M12 female connector NOT included
Enclosure rating	IP66
Electrical contact	Reed Switch 20W/VA
Switching voltage	110 / 220 Vac & 12 / 24 Vdc
Inlet/outlet port	1 1/2" BSPT Male

M12 Plug Sensors Installation

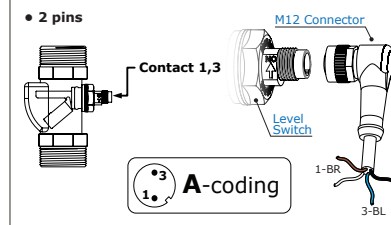

Dimensions (mm) and Weight

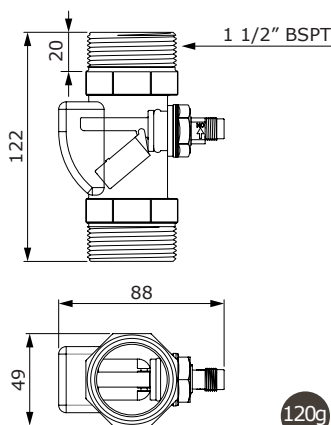

Mounting (Options for Pumps)

NO
Working as
Normally Open

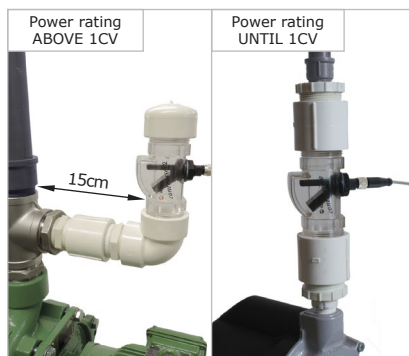

Important!

- For cables longer than 20 meters.
- Relay coupler, timing relay, frequency inverter.

A series **resistor** must be installed.

Click and check how to install.

Typical connection to contactor

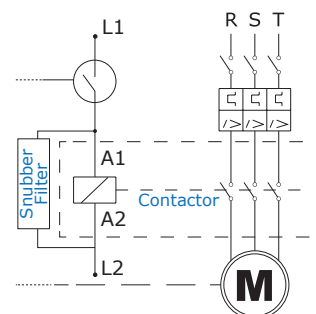

level sensor | float switch | contrasseco | level display | protection | dry running | centrifugal pumps | parallel pipes

Click and Check:
[Models and Prices](#) | [Datasheets](#) | [Operation Videos](#)

Flow Switches and Level Switches for liquids

Make it easy